

FEATURES

- **Compatible with NEMA Size 34**
- **Backlash as Low as 3 arc-min**
- **Gear Ratios from 3:1 to 100:1**
- **Long Design Life, Over 20,000 hrs**
- **Up to 97 Percent Efficiency**
- **Max Input Speeds up to 8,000 RPM**
- **Lifetime Lubrication**
- **Low Noise Helical Gears**

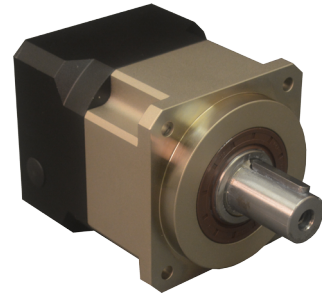

DESCRIPTION

The GBPS-090x Series is an In-Line Planetary Helical Gearbox line that offers great prices without sacrificing precision and quality. The GBPS-090x Series is designed for motion control applications requiring moderate backlash and stiffness. Features include backlash as low as 3 arcminutes, 22 gear ratios for rated torque up to 1328 in-lbs (21,248 oz-in), (model dependent), a precision clamping system and lifetime lubrication. Please verify all dimensions when matching a gearbox to a specific motor, as critical dimensions will vary among series and manufacturers.

SPECIFICATIONS

Model #	Gear Ratio (X:1)	Rated Output Torque (in-lb)	Max Output Torque (in-lb)	Rated Input Speed (RPM)	Max Input Speed (RPM)	Stages	Backlash (arcmin)	L2 Length (mm)	Weight (lbs)
GBPS-0901-NM-003-XXXXX-XXX	3	1283	2309	4000	8000	1	3	46	7.716
GBPS-0901-NM-004-XXXXX-XXX	4	1328	2390	4000	8000	1	3	46	7.716
GBPS-0901-NM-005-XXXXX-XXX	5	1239	2230	4000	8000	1	3	46	7.716
GBPS-0901-NM-006-XXXXX-XXX	6	1195	2151	4000	8000	1	3	46	7.716
GBPS-0901-NM-007-XXXXX-XXX	7	1106	1991	4000	8000	1	3	46	7.716
GBPS-0901-NM-008-XXXXX-XXX	8	974	1753	4000	8000	1	3	46	7.716
GBPS-0901-NM-009-XXXXX-XXX	9	841	1514	4000	8000	1	3	46	7.716
GBPS-0901-NM-010-XXXXX-XXX	10	841	1514	4000	8000	1	3	46	7.716
GBPS-0902-NM-012-XXXXX-XXX	12	1283	2309	4000	8000	2	5	86	12.346
GBPS-0902-NM-015-XXXXX-XXX	15	1283	2309	4000	8000	2	5	86	12.346
GBPS-0902-NM-020-XXXXX-XXX	20	1328	2390	4000	8000	2	5	86	12.346
GBPS-0902-NM-025-XXXXX-XXX	25	1239	2230	4000	8000	2	5	86	12.346
GBPS-0902-NM-030-XXXXX-XXX	30	1239	2230	4000	8000	2	5	86	12.346
GBPS-0902-NM-035-XXXXX-XXX	35	1239	2230	4000	8000	2	5	86	12.346
GBPS-0902-NM-040-XXXXX-XXX	40	1239	2230	4000	8000	2	5	86	12.346
GBPS-0902-NM-045-XXXXX-XXX	45	1239	2230	4000	8000	2	5	86	12.346
GBPS-0902-NM-050-XXXXX-XXX	50	1239	2230	4000	8000	2	5	86	12.346
GBPS-0902-NM-060-XXXXX-XXX	60	1195	2151	4000	8000	2	5	86	12.346
GBPS-0902-NM-070-XXXXX-XXX	70	1106	1991	4000	8000	2	5	86	12.346
GBPS-0902-NM-080-XXXXX-XXX	80	974	1753	4000	8000	2	5	86	12.346
GBPS-0902-NM-090-XXXXX-XXX	90	841	1514	4000	8000	2	5	86	12.346
GBPS-0902-NM-100-XXXXX-XXX	100	841	1514	4000	8000	2	5	86	12.346

Part numbers are based on the specifications of the motor being matched to the gearbox.

-xxxxx denotes motor pilot, -xxx denotes input shaft diameter.

Refer to *Matching the Gearbox to Your Motor* on the second page for more information, or contact an Anaheim Automation Applications Engineer for assistance.

Matching the Gearbox to Your Motor

To ensure compatibility with the gearbox, it is important to consider that the motor specifications are within the listed ranges below. Motor Bolt Circle Diameter, Input Shaft Diameter, Input Shaft Length, Pilot Thickness, Pilot Diameter and Hole Diameter are required in order to match the motor with the appropriate gearbox, and will be used to determine the complete part number. Please see the Gearbox Mounting form downloadable from our website under Support -Technical Support - Installations for more information on required motor data.

Parameter	Range
Bolt Hole Circle Diameter	90mm Max
Input Shaft Diameter	24mm Max
Input Shaft Length	30mm Max
Pilot Thickness	6mm Max
Pilot Diameter	50mm to 70mm
Hole Diameter	Any Size

BUSHING WILL BE SUPPLIED WHEN THE MOTOR SHAFT DIAMETER IS SMALLER THAN 19

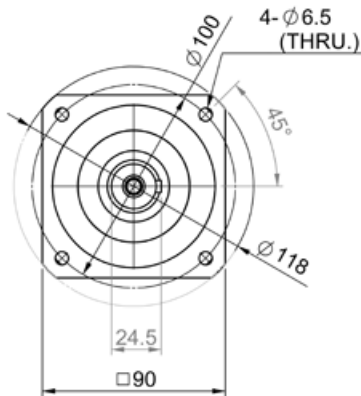

Units in mm

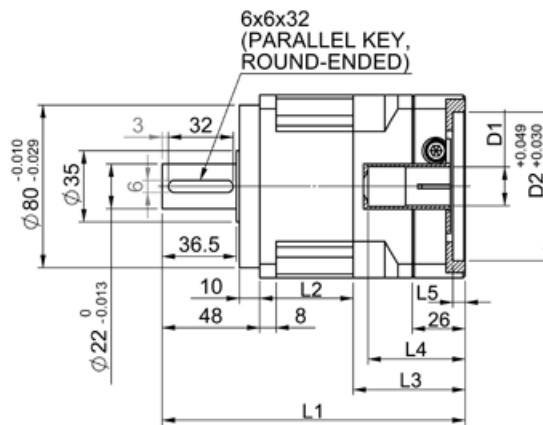

M6x16L
(SOCKET HEAD
CAP SCREW)

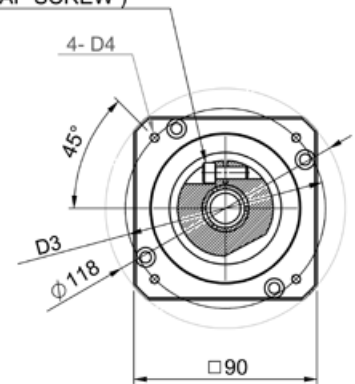

ITEM	DESCRIPTION	MOTOR INTERFACE			
		AA341-500	AA341-625	BLK32-748	EMJ80-748
D1	Input Shaft Diameter	12.7	15.875	19	19
L4	Max Shaft Length	47.8	47.8	47.8	47.8
L3	Motor Mount Length	55	55	55	55
D2	Pilot Diameter	73.05	73.05	70	70
L5	Pilot Depth	6	6	6	6
D3	Mounting Bolt Hole Circle	98.4	98.4	90	90
D4	Bolt Hole Size	M5x10	M5x10	M5x10	M5x10
L1	1-Stage Models, Overall Length	149	149	149	149
L1	2-Stage Models, Overall Length	189	189	189	189



Gearbox Application Sheet

Please return via fax or email: (714) 992-0471, applications@anaheimautomation.com

Name: _____ E-Mail: _____

Company: _____ Phone: _____

Address: _____ Fax: _____

City: _____ State: _____ Zip: _____

Current Quantity Requirements: _____

Estimated Annual Requirements: _____

Motor Specifications:

Units: mm in

Bolt Circle Diameter (D3): _____

Shaft Diameter (D1): _____

Pilot Diameter (D2): _____

Hole Diameter (D4): _____

Pilot Thickness (L5): _____

Shaft Length (L4): _____

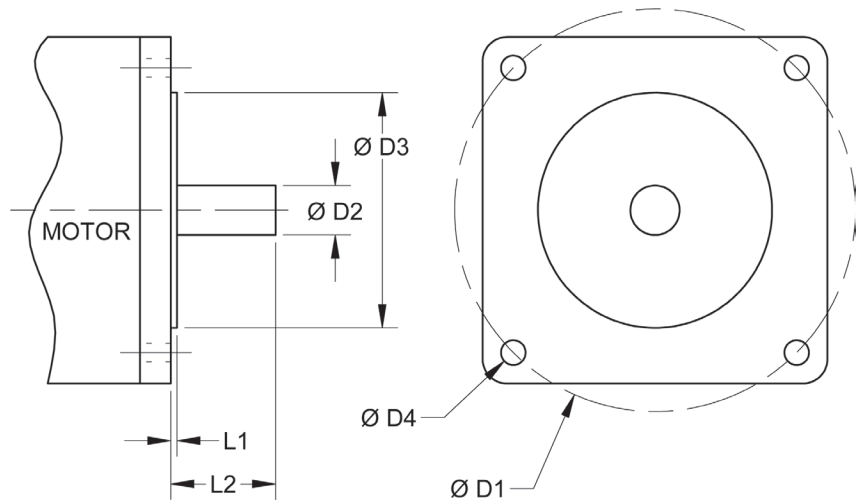

Gearbox Specifications:

Gearbox Part Number: _____

(Please provide an Anaheim Automation Gearbox Part Number if Available)

Please provide any additional information below:

